

Third Semester B.E. Degree Examination, June 2012
Electronic Circuits

Time: 3 hrs.

Max. Marks:100

Note: Answer FIVE full questions, selecting at least TWO questions from each part.

PART – A

- 1 a. Explain the effects of collector resistor, base current and supply voltage on the operating point of a fixed bias circuit. Which is the ideal position for an operating point on the BJT fixed bias transistor circuit? Explain the above with neat diagrams. (10 Marks)
- b. What is the operating point for the following voltage divider bias circuit? (10 Marks)

Assume $\beta = 150$
 $V_{BE} = 0.7 \text{ V}$

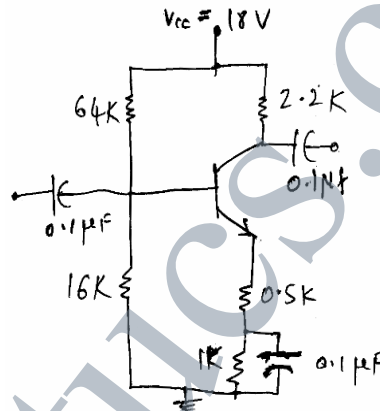

Fig.Q1(b)

- 2 a. Explain the working of a N-channel E-Mosfet with neat diagram. Explain with a diagram output characteristics of the same. (10 Marks)
- b. Find the values of voltages V_D and V_C for the circuit shown, Fig.Q2(b). Assume $\beta = 100$, $V_{BE} = 0.7 \text{ V}$, saturation drain current of JFET is -10 mA and pinch off voltage is -5 V . (10 Marks)

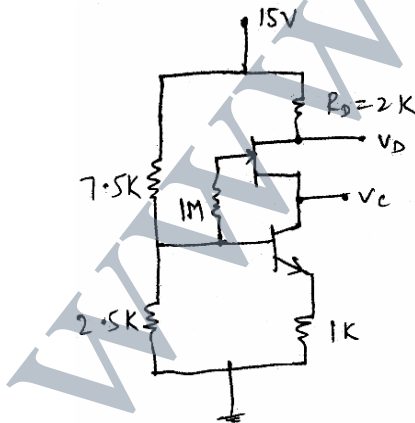

Fig.Q2(b)

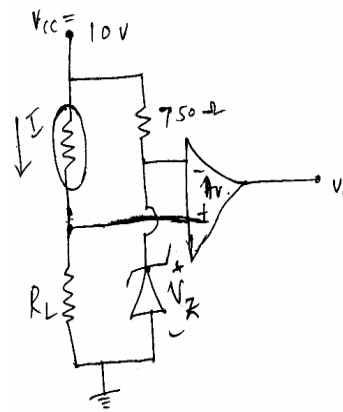

Fig.Q3(b)

- 3 a. Explain photodiode, photosensor, photo conductor and phototransistors with necessary diagrams. (10 Marks)
- b. Find the value of R_L for the circuit shown, Fig.Q3(b) such that the circuit gives a logic high when the light incident on it is above 200 lux and the photo conductor has a resistance of 14 kΩ at a light level of 100 lux, $\alpha = 0.5$, power supply voltage is $V_{CC} = 10 \text{ V}$ and reference voltage of zener diode is 3.5V. (10 Marks)

Important Note : 1. On completing your answers, compulsorily draw diagonal cross lines on the remaining blank pages.
 2. Any revealing of identification, appeal to evaluator and /or equations written eg. 42+8 = 50, will be treated as malpractice.

- 4 a. Graphically how h-parameters of a BJT are determined? Explain with neat diagram. Also derive expression for input impedance and voltage gain for a BJT amplifier. (10 Marks)
- b. Give the hybrid equivalent model for the circuit shown, in Fig.Q4(b). Find input impedance, voltage gain, current gain and output impedance. The h-parameters are $h_{ie} = 1.5 \text{ k}$, $h_{je} = 100$, $h_{re} = 1 \times 10^{-4}$, $h_{oe} = 25 \mu \text{ A/V}$. (10 Marks)

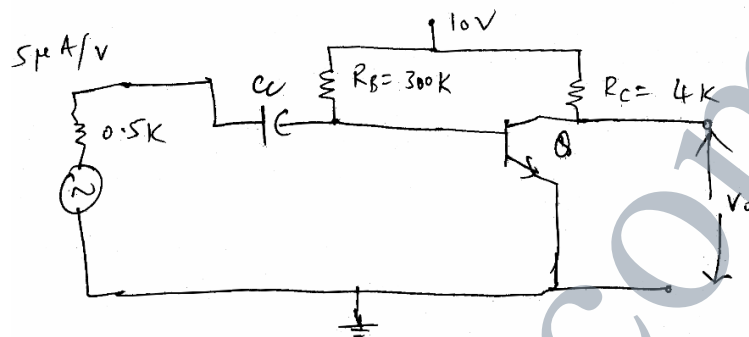

Fig.Q4(b)

PART - B

- 5 a. Discuss large signal amplifier characteristics. Discuss harmonic distortion. Derive A_0 , A_1 , A_2 , A_3 , A_4 , the amplitude of D,C, first, second, third, fourth amplitude of harmonic components. (10 Marks)
- b. Derive expressions for gain, input resistance and output resistance of voltage shunt feedback amplifier with the help of neat diagram. For the opamp based inverting amplifier circuit shown in Fig.Q5(b) find input impedance given that transimpedance, input impedance and output impedance of opamp are $100 \text{ M}\Omega$, $10 \text{ M}\Omega$, and 100Ω respectively (10 Marks)



Fig.Q5(b)

- 6 a. Mention the conditions necessary for oscillations in a feedback amplifier circuit. Determine the frequency at which the following circuit, shown in Fig.Q6(a) would oscillate if the loop gain criterion was met. (10 Marks)

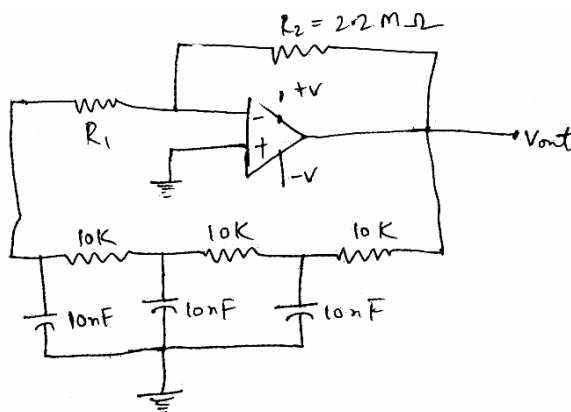

Fig.Q6(a)

Also determine the maximum value of R_1 for sustained oscillation.

- b. With neat diagram and waveforms explain the working of a bistable multivibrator. (BJT based). (10 Marks)
- 7 a. Explain regulated power supply parameters: Load regulation, line regulation, output impedance. Ripple rejection factor. Determine the output ripple of a regulated power supply which provides a ripple rejection of -80dB and a ripple voltage in the unregulated input were 2 V. (10 Marks)
- b. Explain buck regulator boost regulator and inverting regulator with neat diagram. (10 Marks)
- 8 a. Explain with neat diagram: i) Peak detector circuit ii) Absolute value circuit and their working. (10 Marks)
- b. Explain with neat diagram: i) Current to voltage converter ii) Voltage to current converter and their working. (10 Marks)

* * * * *